

# NOVO

Digital Radiography

The Leaders in Portable DR Systems

*NDT*



Oil & Gas



Construction



Shipyards



Aerospace



Munition

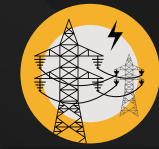

Power Line



Science & Art

INNOVATIVE • COMPACT • RUGGED

# ② Applications

Oil & Gas

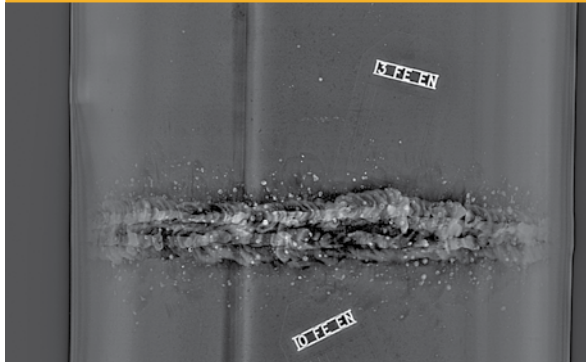

Aerospace

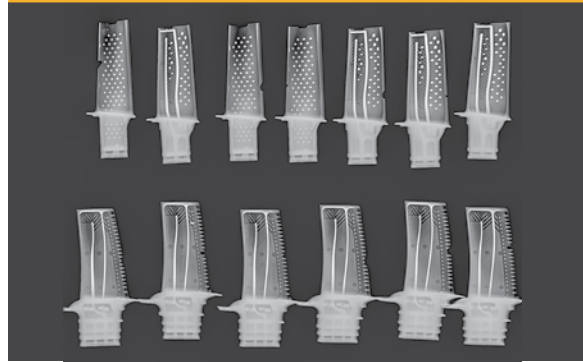

Construction

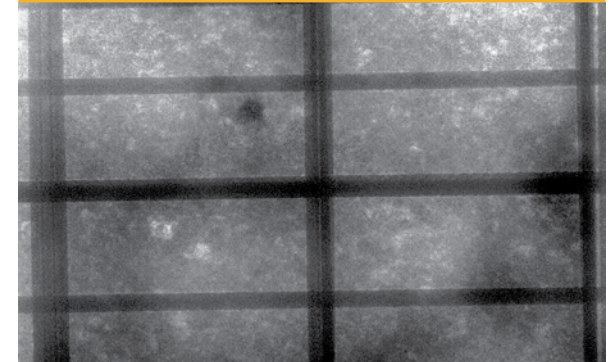

Ship Building

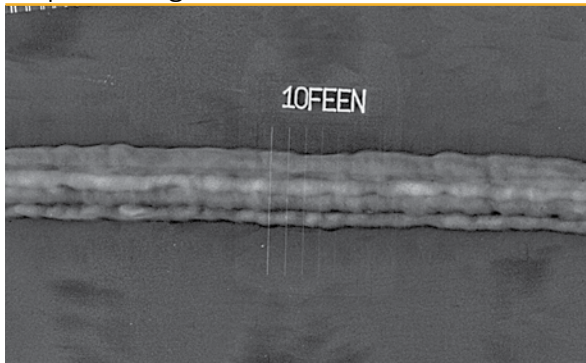

Power Line

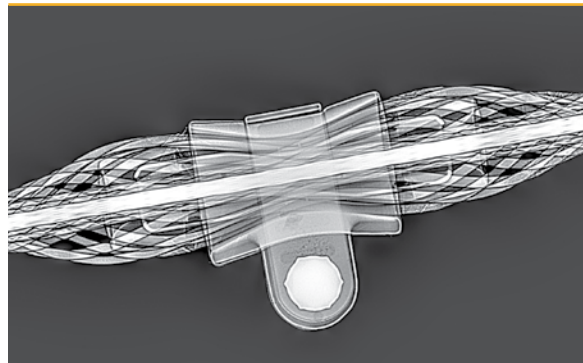

Railways

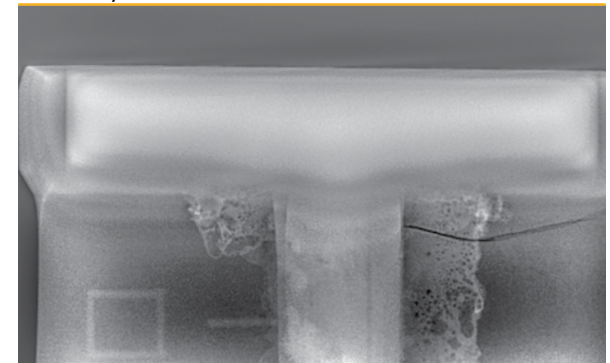

Munition



Science & Art

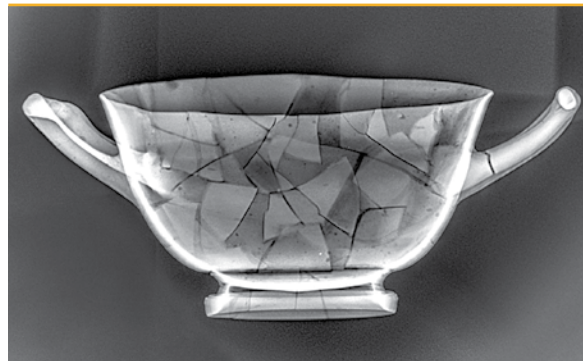

# Highlights



## Highest Image Quality: 16-bit Latest Generation

State of the art Digital Radiography detectors that produce, with a touch of a finger, exceptional high quality images with incredible detail and high penetration capabilities.



## The Genie - One Touch Enhancement Feature

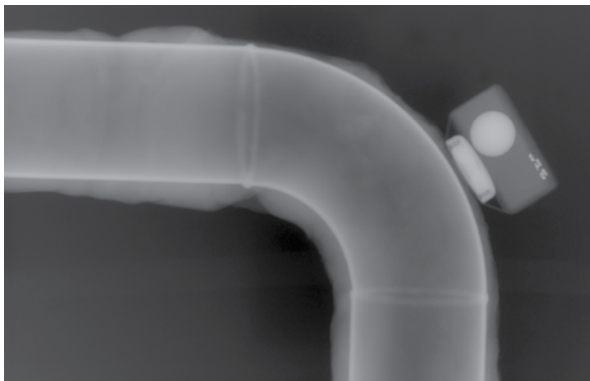

Before

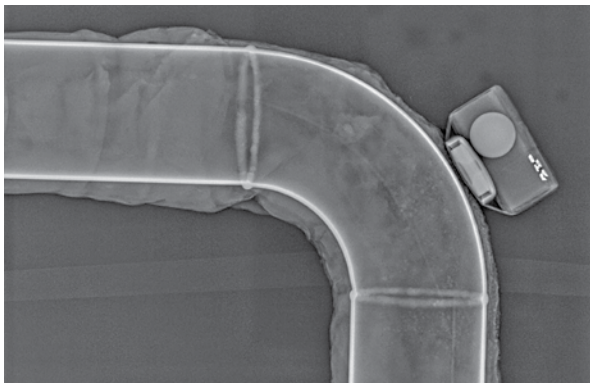

After



## Cutting Edge Detectors: Thinnest, Lightest, most Durable

- Unmatched Image Quality!
- Built-in shielding for maximum life span
- Designed to Operate with High Dose/Energy
- 16-bit Latest Generation
- Detector Thickness from 0.6" (15.6mm)
- Drop Tested Detectors
- Load Proof 661 lbs. (300 kg)
- Lightest in the Market

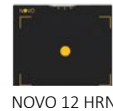

NOVO 12 HRN



NOVO 15WN

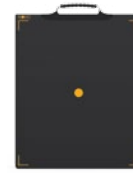

NOVO 22WN



## Versatile System Casing: Complete System in a Pelican Hard Case

- Each system includes:
- Detector
  - Tablet & NOVO Touch Software
  - X-Ray Source
  - Control Box / Falcon
  - Custom Communication Reel
  - Additional Modules & cables



Optional Backpack configurations



## Most Rugged System: Suitable for all Terrain and Weather Conditions

- Usage in Extreme Weather Conditions
- MIL-DTL 38999 Connectors
- Titanium Magnetic Connectors
- Proprietary Design Cables
- MIL-STD-810G Tablets
- Drop Tested Detectors
- Rugged Cases

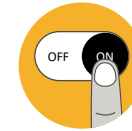

## Touch Software: Simple User Friendly Touch Interface

- Operating & Controlling the System
- Powerful Automatic Enhancing Algorithms
- Optimal Viewing Experience
- Supports Various International Standards
- Variety of Tablets; rugged 7" up to a 20" display.
- Windows® 10

Windows 10



## Parallel Multi Location Control & Display:

True Multi Tablet Control and Display allows for multiple display units to be connected to the system. Multiple team members can control the X-Ray and view the images at different locations.

These tablets can be used to:

- Control the System
- Display X-Ray Images
- Image Enhancing, Storage & Sharing.

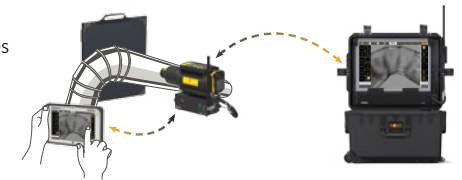

## Unmatched Communication Range: Wired & Wireless Comm.

- Up to 300m Wired Communication
- 400m (0.25miles) LOS Standard Wireless Ranger
- 3.3km (2 miles) LOS Wireless Communication using the NOVO Eagle
- Variety of Wireless Accessories
- Multiple Reels and Cable Options





# NOVO Touch Professional Software

The NOVO Touch Professional Software is NOVO's proprietary software developed from the ground up to provide the best experience and functionality for field & laboratory operations.

- User friendly, native touch interface
- Intuitive operation for grabbing X-Ray images, annotating, archiving and sharing information
- Built-in tools such as the Genie, Line Profile, SRb, DWT, Stitching, Image Statistics and more
- Supports various International Standards
- Supports different file formats such as **TIF**, **DICOM**
- Controls various hardware features such as illumination, switch from wired to wireless communication, activates a variety of X-Ray sources and more
- Compatible with the latest touch screen technology & standard PC's operating with Windows® 10

## Software Features

- GENIE - One Touch Enhancement
- Auto SRb (Basic Spatial Resolution)
- Line Profile
- DWT (Double Wall Thickness )
- Manual & Automatic Stitching
- Averaging (Frame Integration)
- Image Statistics
- Wall Thickness Measurement
- 1600% Zoom
- Semi Automatic Measurements
- Annotations-Text, Shape Etc.
- Audio Documentation

and many more....

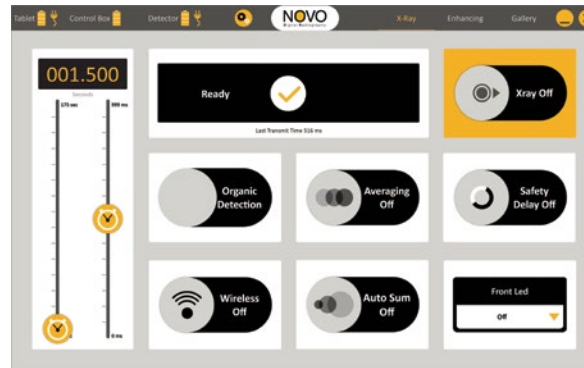

**X-Ray Screen**

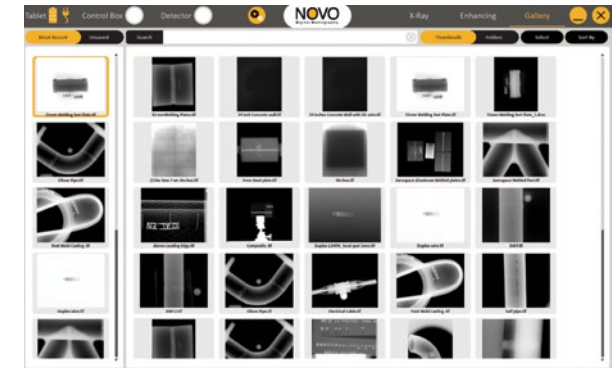

**Gallery Screen**

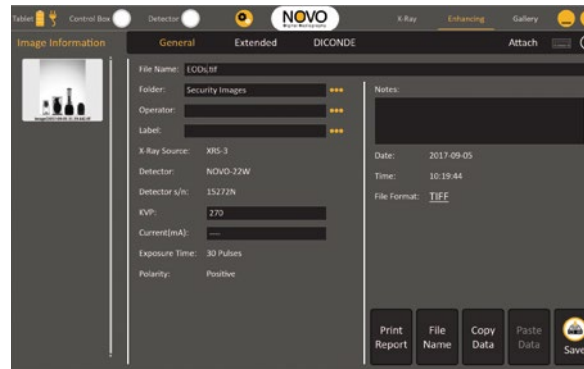

**Save/Data Screen**

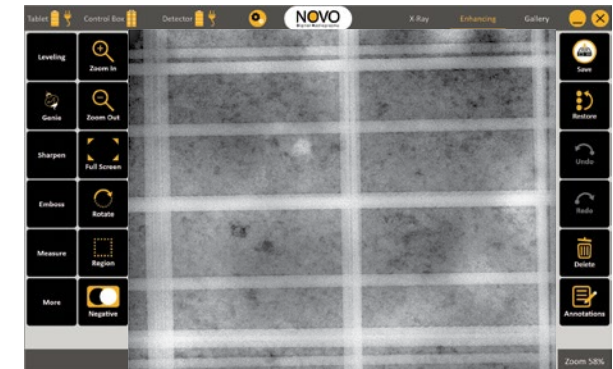

**Enhancing Screen**

### **Rebars through a 15.2cm concrete wall**

Detector: NOVO 22WN

KVP: 225kv

Current: 3mA

Exposure time: 7s



### The Genie Enhancement Feature

Proprietary, State-of-the-art algorithm that provides an unprecedented, perfect image with ALL (Easy & Hard to penetrate materials) the information shown with a single touch

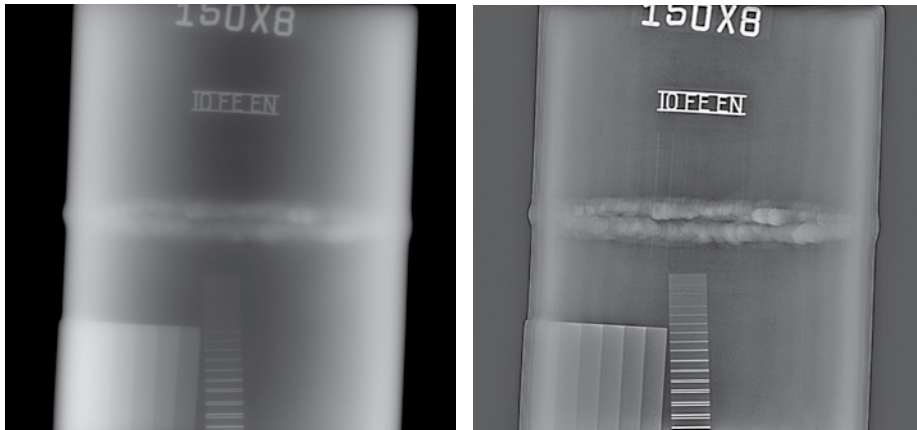

Before

After

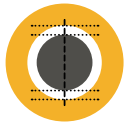

### Line Profile

Fast, Easy & Automatic Wall Thickness Measurements

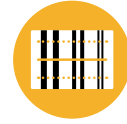
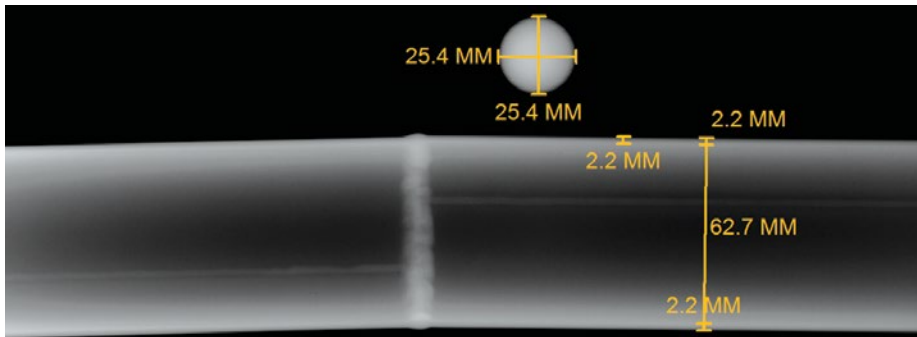

### SRb (Basic Spatial Resolution) Feature

Select the Region of Interest and leave the rest to NOVO's Automatic Basic Spatial Resolution Tool

Name	D	R (%)	DDRD
1 D	0.800	96.213	22519.26
2 D	0.630	96.848	22820.57
3 D	0.500	95.242	22391.71
4 D	0.400	93.839	22388.71
5 D	0.320	90.617	22215.94
6 D	0.250	84.988	21916.71
7 D	0.200	76.041	21797.20
8 D	0.160	62.125	21784.86
9 D	0.130	53.350	21626.29
10 D	0.100	31.659	21616.23
11 D	0.080	21.987	21636.34
12 D	0.063	0.000	0.00

Spatial Resolution 0.078 mm  
Angle 3.23 deg

Region of Interest

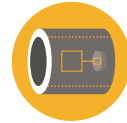

### DWT

Simple & Intuitive Double Wall Thickness Technique Tool- Converting Gray Levels into Material Thickness

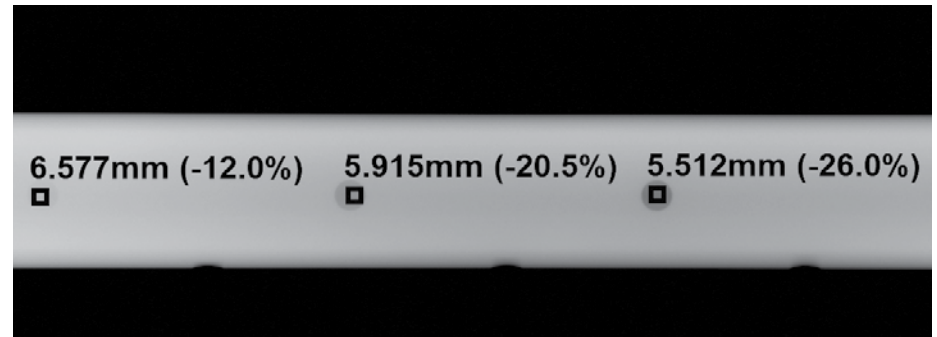

# 6 NOVO Touch Professional Software



## Stitching Feature

Stitch Multiple images into one large image using our Easy To Use, Manual Stitching Feature or our Extremely Fast, Automatic Stitching Feature

Before Multiple X-Ray Images

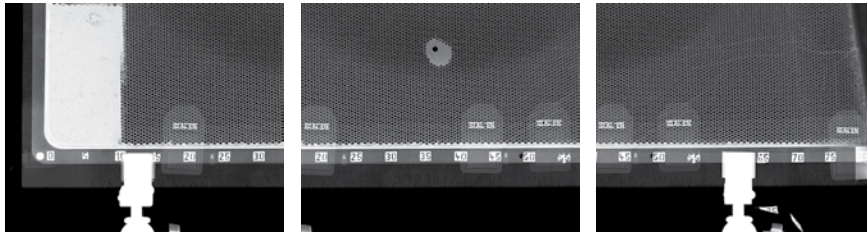

After One Large X-Ray Image

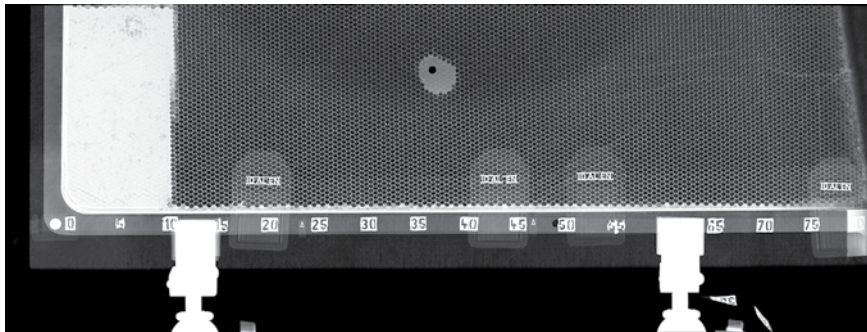

## International Standards

The NOVO Touch Professional Software can archive, share and process image reports. In addition, the Native Touch Software has numerous measuring tools and enhancement features all of which provide the necessary tools to support multiple international standards such as:

- ISO 17636-2 Class B
- BOEING 7044 Ver C
- ASME Section V article 2
- ASTM DICONDE

## Samples Images

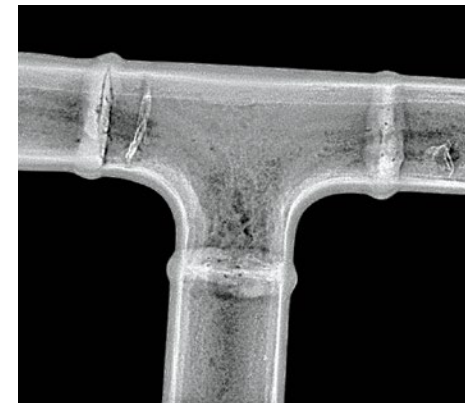
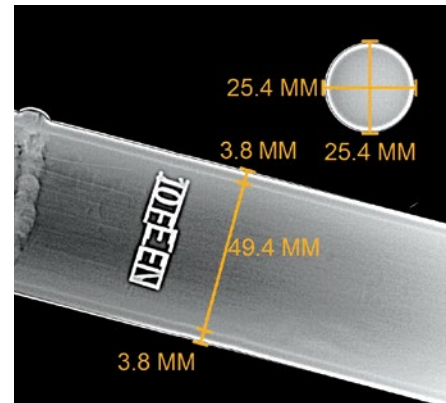
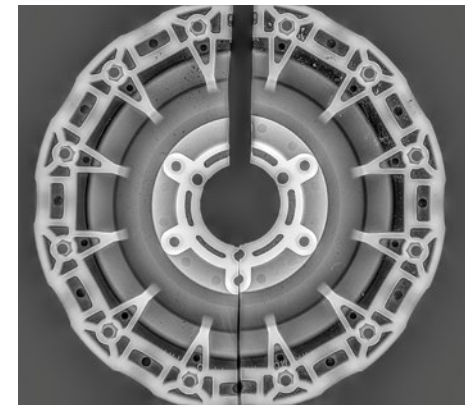
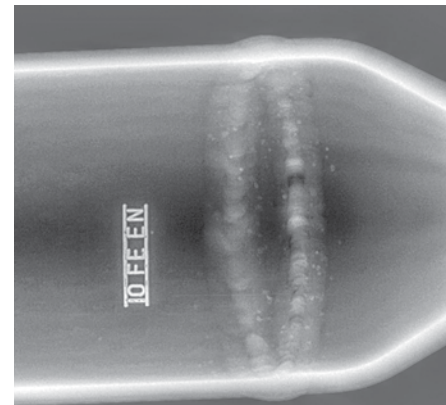

# Discovery Systems

The NOVO Discovery systems provide a complete solution for the NDT radiography professionals as they are specially designed for working in tough field conditions, yet having all the tools required.

- Supports the operation of NOVO's 12HRN, 15WN & 22WN Detectors
- Unlimited operation when external power is connected
- Wired & Wireless Communication
- 10" to 20" 4K Touch Display
- Customized 2750 Pelican case on wheels
- Synchronization with a variety of X-Ray sources
- Space for Golden X-Ray Sources- XR150, XR200 and XRS3



## NOVO 12/15/22 Discovery Systems

1. NOVO 12HRN, 15WN or 22WN Detector\*
2. Detector Stand
3. Panasonic Toughpad FZ-G1 Rugged 10" Tablet & NOVO Touch Professional Software
4. NOVO Control Box
5. Power & Communication Hub
6. Pelican iM2750 Custom Hard Case
7. Wireless Ranger USB
8. Comm. Cable On Rugged Reel: 50m



## NOVO 12/15/22 Discovery 4K Systems

1. NOVO 12HRN, 15WN or 22WN Flat Panel Detector\*
2. Detector Stand
3. Panasonic Toughpad 4K Tablet (20") & NOVO Touch Professional Software
4. NOVO Control Box
5. Power & Communication Hub
6. Pelican iM2750 Custom Hard Case
7. Wireless Ranger USB
8. Comm. Cable On Rugged Reel: 50m



\*Each system contains one of three of NOVO's Detectors, select the size that best suits your needs. Note that a chaser Detector can be purchased separately

# Inspector Systems

The NOVO Inspector systems provide a lightweight, rugged solution for the NDT radiography professionals working out in the field.

- Supports the operation of NOVO's 12HRN, 15WN & 22WN Detectors
- Wired & Wireless Communication
- 10" Rugged Touch Display
- Customized 2720 Pelican case on wheels
- Synchronization with a variety of X-Ray sources
- Space for Golden X-Ray Sources- XR150, XR200 and XRS3



NOVO 12HRN

NOVO 15WN

NOVO 22WN

## NOVO 12/15/22 Inspector Systems

1. NOVO 12HRN,15WN or 22WN Detectors\*
2. Detector Stand
3. Panasonic Toughpad FZ-G1 Rugged 10" Tablet & NOVO Touch Professional Software
4. NOVO Falcon Controller & Charger Kit
5. USB to Comm Adapter
6. Wireless Ranger USB
7. Pelican Storm iM2720 Custom Hard Case
8. Comm. Cable On Mini Reel: 50m

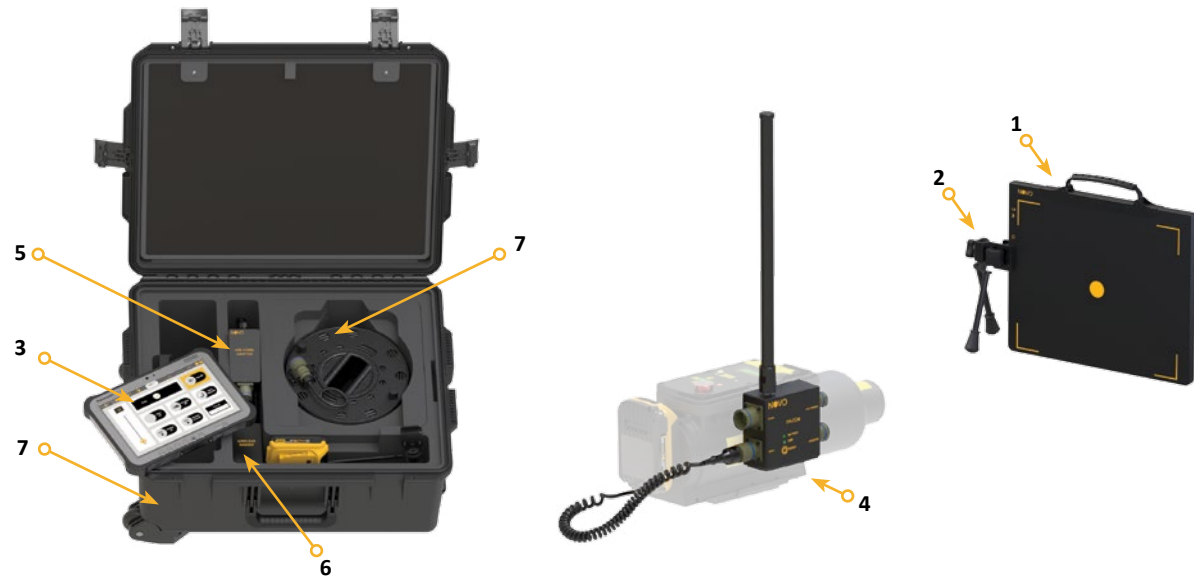

\*Each system contains one of three of NOVO's Detectors, select the size that best suits your needs. Note that a chaser Detector can be purchased separately



# Cabinet & Laboratory Systems

The NOVO Cabinet & Laboratory systems are lightweight, durable configurations that allow for an easy connection to existing X-Ray Cabinet/ Laboratory setups and provide a convenient solution for Digital operation when working in lab or cabinet environments.

- Supports the operation of NOVO's 12HRN, 15WN & 22WN Detectors
- Wired Communication
- Synchronization with a variety of X-Ray sources



## NOVO 12/15/22 Laboratory Systems

1. NOVO 12HRN,15WN or 22WN Detectors\*
2. NOVO Touch Professional Software
3. NOVO Smart Box PC Side
4. NOVO Smart Box Detector Side
5. Comm. Cable: 50m\*\*

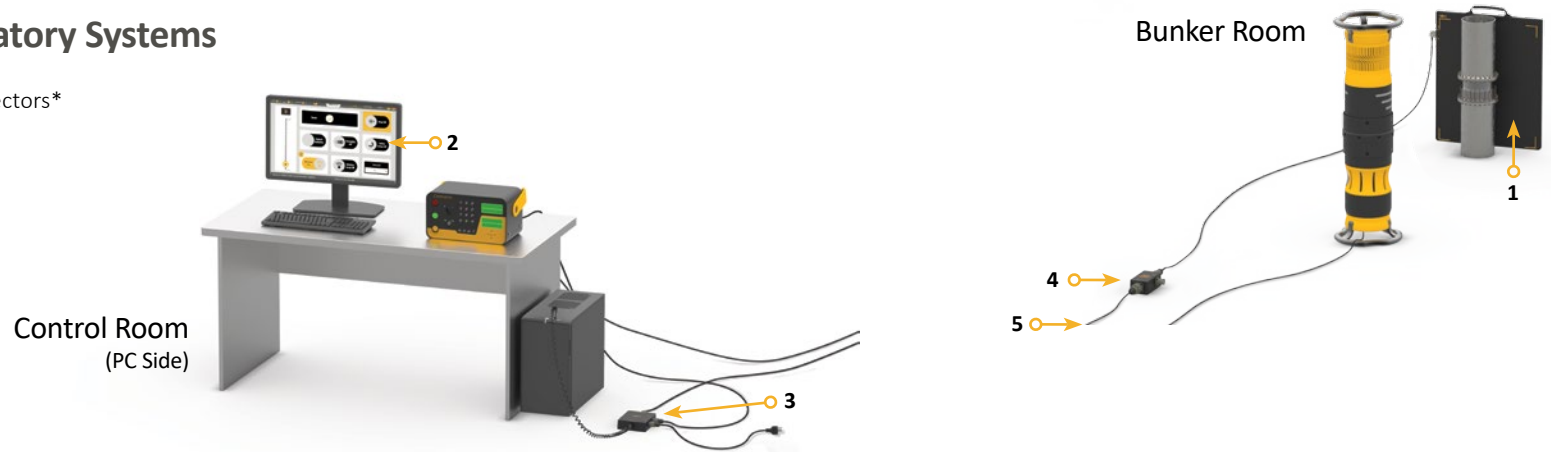

\*\* Maximal Cable length 100m

## NOVO 12/15/22 Cabinet Systems

1. NOVO 12HRN,15WN or 22WN Detectors
2. NOVO Touch Professional Software
3. NOVO Smart Box PC Side
4. Comm. Cable

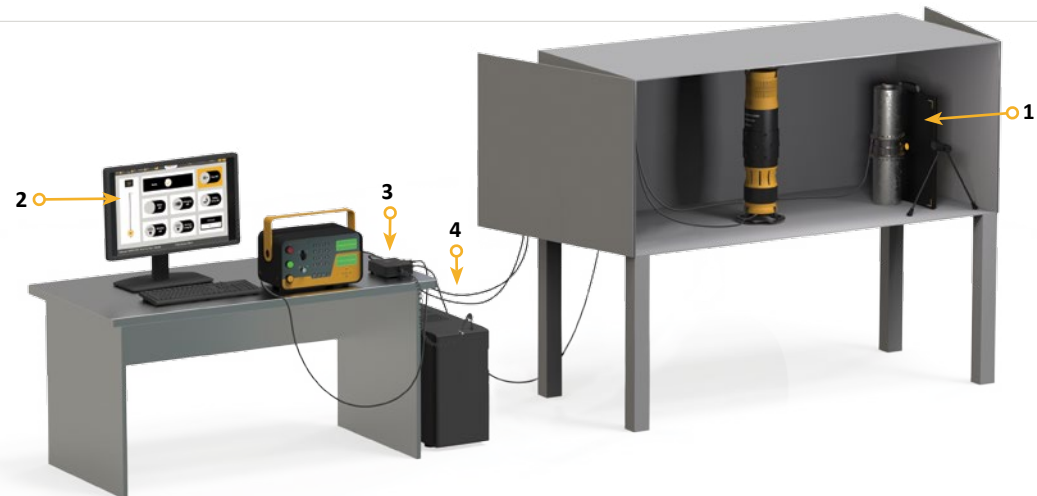

\*Each system contains one of three of NOVO's Detectors, select the size that best suits your needs. Note that a chaser Detector can be purchased separately

# Components

## NOVO 12HRN Detector

The NOVO 12HRN Detector is a High Resolution, **Amorphous Silicon** Technology Detector with a **75µm pixel size**. When needed this technology allows for long exposure times (for high thickness materials) while keeping a very low noise level unlike other technologies such as CMOS.

This technology, together with the NOVO Professional Touch Software makes NOVO DR the first company with a DR system that supports the **ISO 17636-2 Class B** requirements for the **entire** thickness range while using **One** Detector only!

- 75µm pixel size
- Supports ISO 17636-2 Class B requirements from under 1mm and up to >50mm of steel
- Reduced averaging (frame integration) needed due to very low noise
- Minimal dead space – Active area starts 3mm from the bottom of the detector
- Quick removable, rechargeable battery
- Wireless & wired operation
- Removable handle

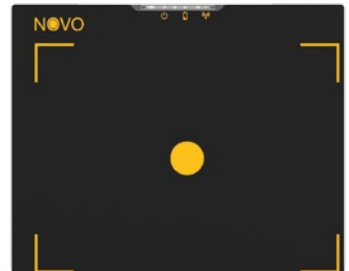

NOVO 12 HRN Detector

Detector Model	NOVO 12HRN
Detector Imaging Area	6.8" x 9.0" (17.3cm x 22.9cm)
Detector Size	8.2" x 10.1" (20.8cm x 25.6cm)
Active Area (Imaging Area / Detector Size)	74% Active Area
Detector Weight	5.3 lbs. (2.4kg)
Detector Load Proof	661 lbs. (300kg)
Detector Drop Test	20" (50cm)
Detector Thickness	1.1" (27.5mm)
Bit Depth	16 bit
Life Span	Over 100K rem*

\* Over 100K rem of direct exposure on the detector

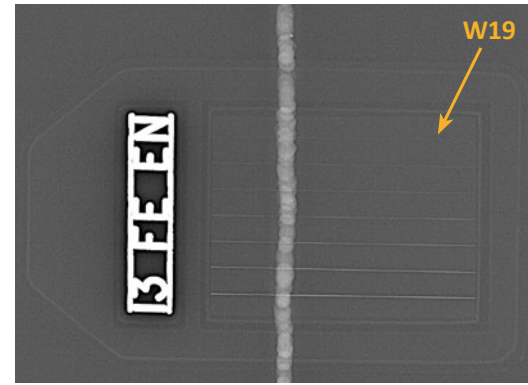

### 2mm Stainless Steel Plate

*IQI Source Side - W19*  
 Class B Compliant  
 Detector: NOVO 12 HRN  
 KVP: 160kv  
 Current: 0.5mA

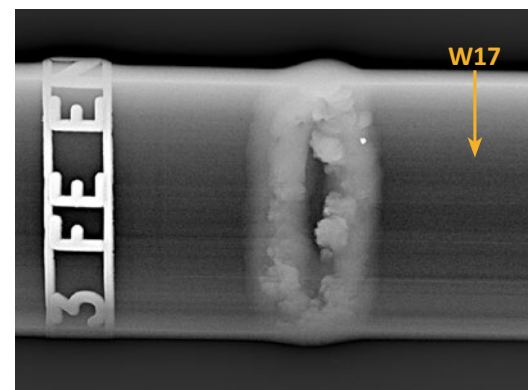

### Stainless Steel Pipe 6mm Penetrated Thickness

*IQI Source Side - W17*  
 Class B Compliant  
 Detector: NOVO 12 HRN  
 KVP: 160kv  
 Current: 0.5mA

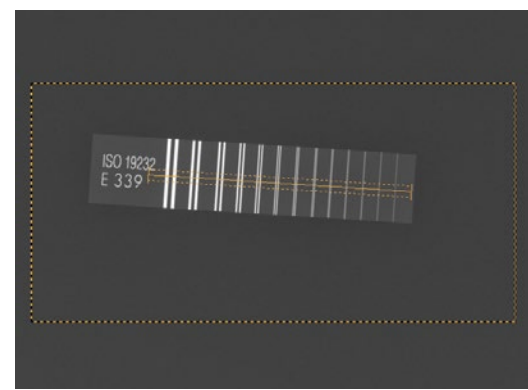

### Duplex Wire

*According to ISO 17636-2*  
 Spatial Resolution - **D12 (63µm)**  
*According to Boeing 7044 Ver C*  
 Spatial Resolution - **less than 80µm**

## 15WN & 22WN Detectors

The NOVO 15WN and NOVO 22WN Detectors provide outstanding image quality in a rugged, durable, thin design and are the latest in DR imaging technology.

- Built-in shielding for maximum life span
- High dose Compatible
- Dual direction titanium magnetic connector
- Quick removable & rechargeable battery
- Wireless & wired operation
- Specifically designed for fieldwork & harsh weather conditions

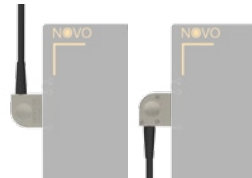

Dual Direction Titanium Magnetic Connector

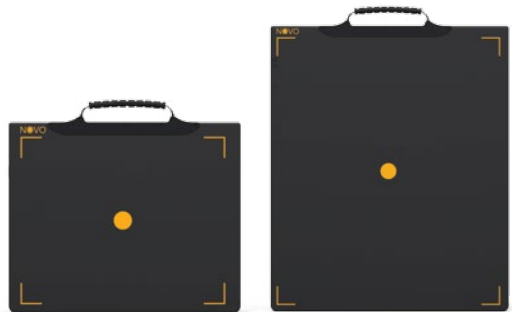

NOVO 15WN

NOVO 22WN

Detector Model	NOVO 15WN	NOVO 22WN
Detector Imaging Area	9.1" x 11.2" (23.1cm x 28.4cm)	14.0" x 16.8" (35.6cm x 42.7cm)
Detector Size	10.6" x 13" (26.9cm x 33cm)	15.2" x 18.2" (38.5cm x 46.2cm)
Active Area (Imaging Area / Detector Size)	74% Active Area	85% Active Area
Detector Weight	5.5 lbs. (2.5kg)	9.9 lbs. (4.5kg)
Detector Load Proof	661 lbs. (300kg)	661 lbs. (300kg)
Detector Drop Test	20" (50cm)	20" (50cm)
Detector Thickness	0.6" (15.6mm)	0.6" (15.6mm)
Bit Depth	16 bit latest generation	16 bit latest generation
Life Span	Over 100K rem*	Over 100K rem*

\* Over 100K rem of direct exposure on the detector

## Tablets

NOVO offers a variety of tablets that can be operated from our customized case or used handheld.

- Pre-installed with the NOVO Touch Professional Software.
- Used to control the system's operation
- One or multiple parallel location control & display
- Ruggedized Tablets
- Rugged 7" up to a 20" display
- A variety of Laptops Available
- Supports Windows® 10



Panasonic Toughpad™ FZ-G1 10"

Panasonic Toughbook® CF-33

Panasonic Toughpad™ 20" 4K

	Panasonic Toughpad™ FZ-G1	Panasonic Toughbook® CF-33	Panasonic Toughpad™ 4K
Screen Size	10.1"	12"	20"
Screen Resolution	1920x1200	2160x1440	3840x2560 (4K)
Screen Brightness (NIT)	800	1200	300
Multi-Touch	10 point, glove touch	10 point, glove touch	10 point touch
Operating System	Supports Windows 10	Supports Windows 10	Supports Windows 10
Weight	2.5 lbs. (1.1 kg)	3.4 lbs. (1.5 kg)	5.27 lbs. (2.4 kg)
Military Standard	MIL-STD-810G	MIL-STD-810G	N/A
Dust & Water Resistance	IP65	IP65	N/A
Drop Rating	4 ft (1.2m)	4 ft (1.2m)	1 ft (30cm)

# Components

## Cases

NOVO Offers a variety of customized cases for a wide range of applications.

- Customized internal & external design
- Rugged
- Smallest Foot Print
- Lightweight
- Hard Cases & Backpacks Available

### NOVO's Hard Cases



Inspector Case

Discovery Case

### NOVO's Backpacks



Tactical II Backpack

Ultimate Backpack

NOVO's Customized Cases	Description	Case External Dimensions
Discovery Case	Rugged iM2750 Pelican™ case	24.6" x 19.7" x 14.4" (62.5cm x 50cm x 36.6cm)
Inspector Case	Rugged iM2720 Pelican™ Case	24.6" x 19.7" x 11.7" (62.5m x 50cm x 29.7cm)
Ultimate Backpack	NOVO's Customized Ultimate backpack	23.0" x 17.3" x 9.45" (58cm x 44cm x 24cm)
Tactical II Backpack	5.11 All Hazards Prime Backpack	11.5" x 7.5" x 20.5" (29.2cm x 19.1cm x 52.1cm)*

\* Main compartment dimensions

## X-Ray & Gamma Sources

NOVO's systems are designed to operate with Isotopes, Constant Potential, Microfocus X-Ray Sources & the entire range of Golden Engineering pulse X-Ray sources

- Reduced dose, increased safety, improved productivity, prolong tube life and enable Isotopes usage at a very low curie due to much higher detection sensitivity
- Operational safety distance is easily obtained with wired or wireless capabilities
- Specially designed connector/picatiny connects the Golden source to the Control Box for quick deployment
- The Golden X-Ray sources are portable, battery operated, lightweight & contain no radioactive materials



Constant Potential

Gamma Source

XR200

XRS-3

XRS-4

	XR200	XRS-3	XRS-4
KVP	150	270	370
Weight	10.7 lbs. (4.8 kg)	11.8 lbs. (5.3 kg)	18.3 lbs. (8.3 kg)
Size	10.7" x 4.3" x 5.8" (27.2cm x 10.8cm x 14.8cm)	14.2" x 4.3" x 5.8" (36.1cm x 10.9cm x 14.8cm)	19.3" x 4.8" x 7.1" (48.9cm x 12.2cm x 17.9cm)
Pulse Rate	10 pulses per second	15 pulses per second	9 pulses per second

# Components- Controllers

## Control Box

The Control Box is NOVO's fully featured Controller. It can provide 16 hours of battery operation as well as continuous operation when AC Power is available.



	Weight	Unlimited operation with AC	Built-in Battery	Wired/Hybrid	Wireless	Supports All Golden Sources	Picatinny quick connection to source	Elevates X-Ray Source	MIL-DTL 38999 connectors	Weatherproof design	LED Indications	White LED flashlight	Infra-red flashlight	Siren Indication when X-Ray fires	Supports Parallel Multi Location Control & Display	Supports the NOVO Lookout and Folding Slider
<b>NOVO Control Box</b>	5.3 lbs. (2.4 kg)	✓	16 hours	✓	400m Line of Sight	✓	✓	✓	✓	✓	✓	✓	✓	✓	✓	✓

### Control Box Wireless Set Up:



### Control Box Wireless Set Up:

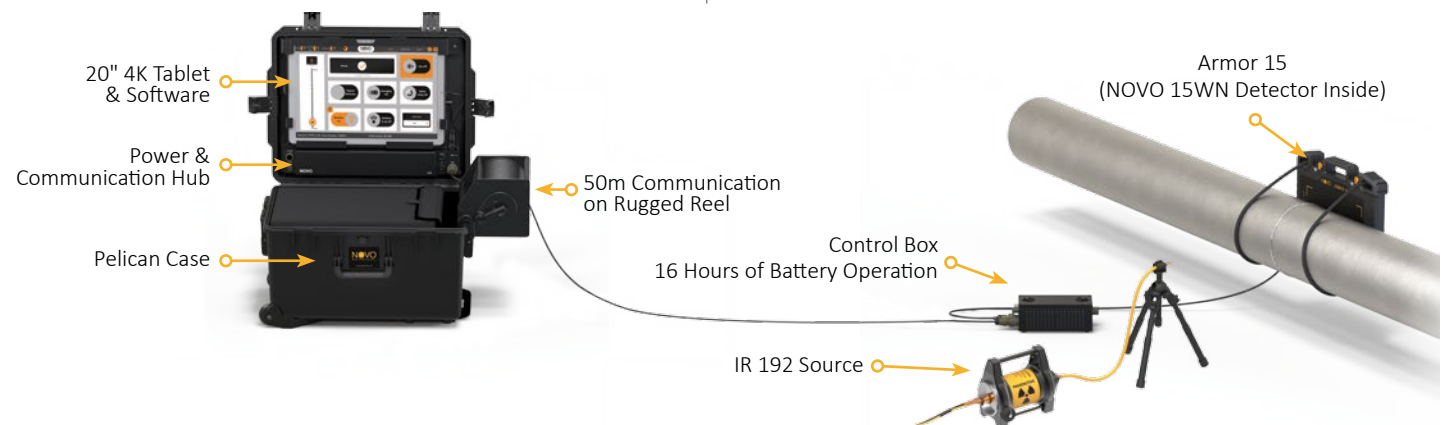

# Components- Controllers

## NOVO Falcon

The NOVO Falcon supports both Wired and Wireless Commutation while keeping the controller's weight at a minimum.



	Weight	Unlimited operation with AC	Built-in Battery	Wired/Hybrid	Wireless	Supports All Golden Sources	Picatinny quick connection to source	Elevates X-Ray Source	MIL-DTL 38999 connectors	Weatherproof design	LED Indications	White LED flashlight	Infra-red flashlight	Siren Indication when X-Ray fires	Supports Parallel Multi Location Control & Display	Supports the NOVO Lookout and Folding Slider
<b>NOVO Control Box</b>	1.7 lbs. (0.8 kg)	✗	6 hours	✓	400m Line of Sight	✓	✓	✗	✓	✓	✓	✗	✗	✗	✗	✓

### Falcon Wireless Set Up:



### Falcon Wired Set Up:

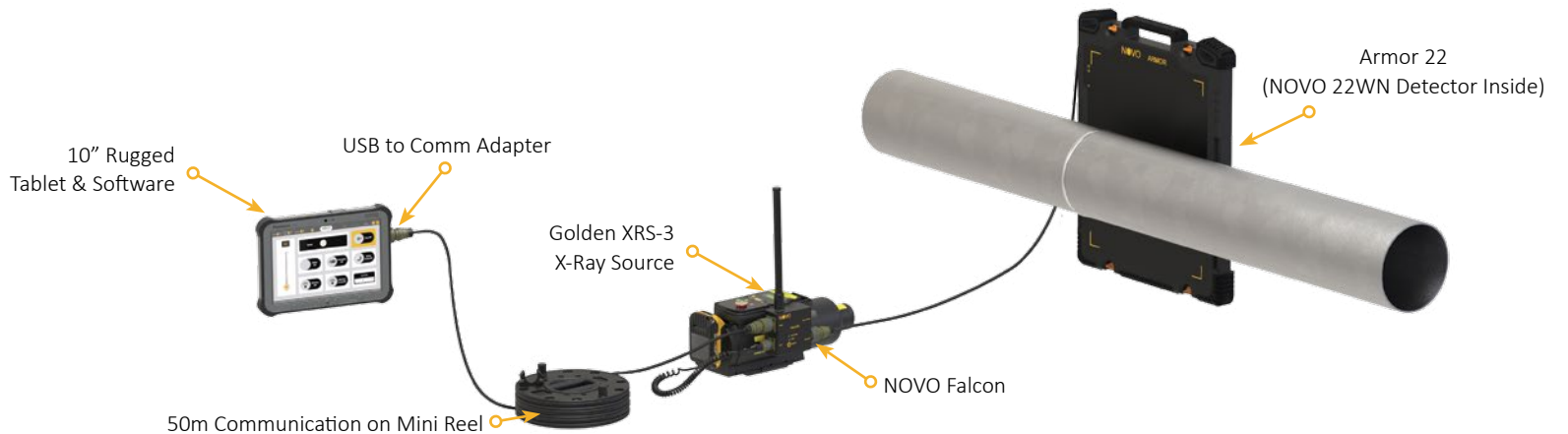

# Accessories

## Power & Communication Hub

The Power & Communication Hub is attached to NOVO's Discovery 25" Pelican™ Case and allows Wired Communication with the entire system and provides Power when external power is connected.

- MIL-DTL 38999 Connectors
- Fast data USB 3 ports
- AC outlet



Power & Communication Hub

## Communication Cable

The communication cable provides reliable and fast data transmission between the various system parts.

- Proprietary rugged cable suitable for working in extreme weather conditions
- Power transmission for unlimited operation when using an external power source (Discovery Systems with Control Box)
- Lightweight, robust custom reel- connected to the case or as “stand-alone”
- Extension cables of 50m, 100m and 150m
- Maximum of 300m wired operation range

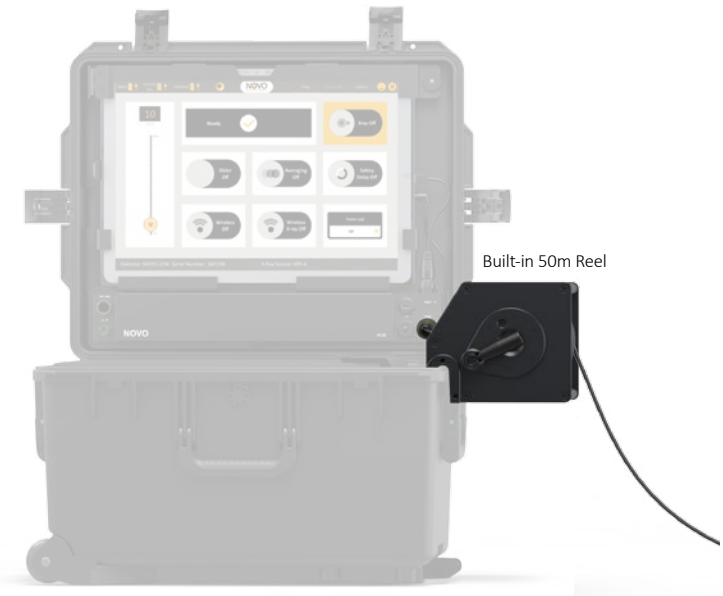

Built-in 50m Reel



Extension Reel



Custom Reel for Inspector System

# Accessories

## Eagle - Long Range Wireless

The NOVO Eagle is an Extremely Long Range Wireless transceiver, which connects between the display unit and the Detector and X-Ray source.

- Connects Tablet to Detector & X-Ray source
- 3.3km (2 miles) line of sight
- Fully wireless or hybrid communication
- 1/4" standard threading for tripod connection
- 5 Hours of internal battery operation

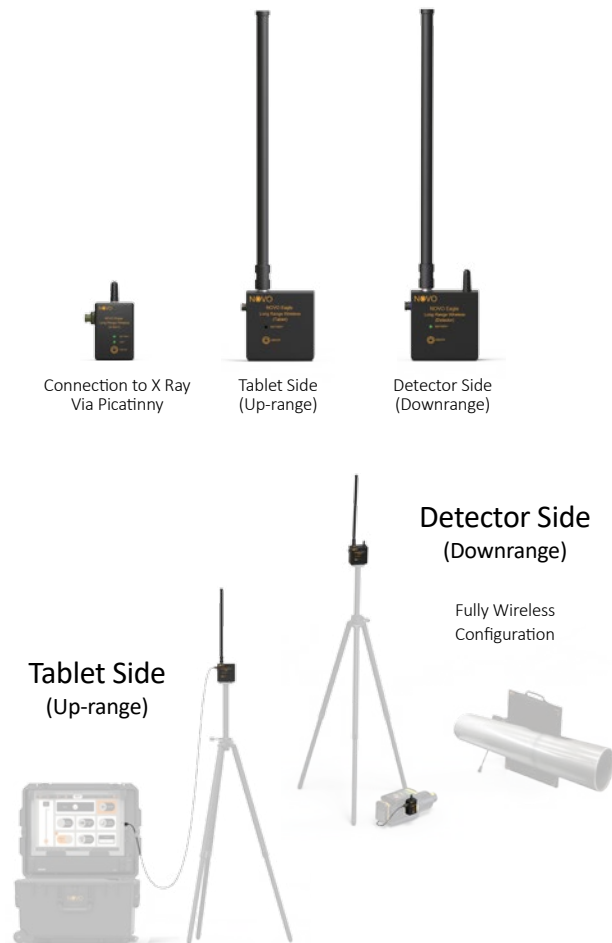

\*Tripods not included

## NOVO Wireless Spark III

The Wireless Spark III is NOVO's Extremely Lightweight, Small footprint Controller. The Spark III is the Ideal controller when a system with minimum weight is required.

- 6 Hours of operation
- 400m Line of Site
- Picatinny/Magnetic quick connection to Golden X-Ray sources
- MIL-DTL 38999 connectors
- Weatherproof design



NOVO Wireless Spark III

## Wireless Ranger

The NOVO Wireless Ranger is a wireless transceiver, which extends the wireless communication range between the tablet and the Detector.

- Battery-free
- Lightweight
- Staggering 400m line of sight
- Built in magnets to mount on any ferromagnetic object – tablet, case, vehicle etc.





## Armor

The Armor provides additional mechanical protection to the NOVO 12HRN, 15WN & 22WN Detectors. The Armor has built-in 1/4" threads for mounting the Armor on tripods as well as a custom Armor stand for upright positioning.

- Newest shock absorbent technology
- Water resistant design
- Supports wired & wireless communication
- Multiple positioning options
- Tripod connection using the Built-in 1/4" threads
- Simple Detector battery replacement



NOVO Armor 22



NOVO Armor 15



NOVO Armor 12



NOVO Armor Stand



NOVO Detector

NOVO Armor

## Soft Protective Cover

The Detector Soft Protective Cover provides additional protection for the NOVO 12HRN, 15WN & 22WN Detectors.

- Weather & impact protection
- Special opening for Tripod Mount access
- Various positioning options using a carrying strap or D-Rings
- Supports wired & wireless communication
- Lightweight & small



# Accessories

## Tripod Mounts

The Tripod Mount is a lightweight accessory that firmly holds the detector and provides various positioning options.

- Two 1/4" standard threads for tripod or manipulation arm connection
- Secured connection to the Detector using a safety pin
- Numerous positioning options

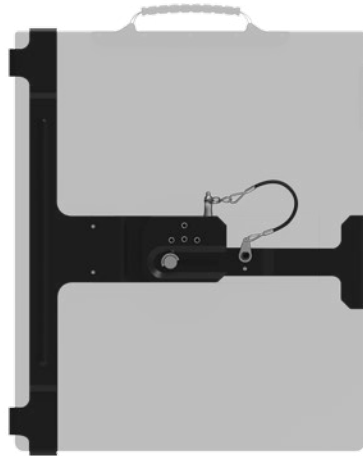

NOVO 22 Tripod Mount  
~1lbs. (~0.5kg)

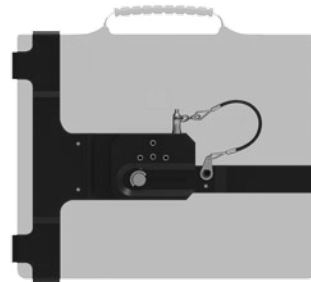

NOVO 15 Tripod Mount  
~0.9lbs. (~0.4kg)

## Detector Stand

The Detector Stand is a custom-made accessory that firmly holds the Detector in an upright position (portrait or landscape).

- Low profile design
- Utmost flexibility in tight places
- Multiple positioning options- standalone (figure a) or leaning on a wall (figure b)



Figure a

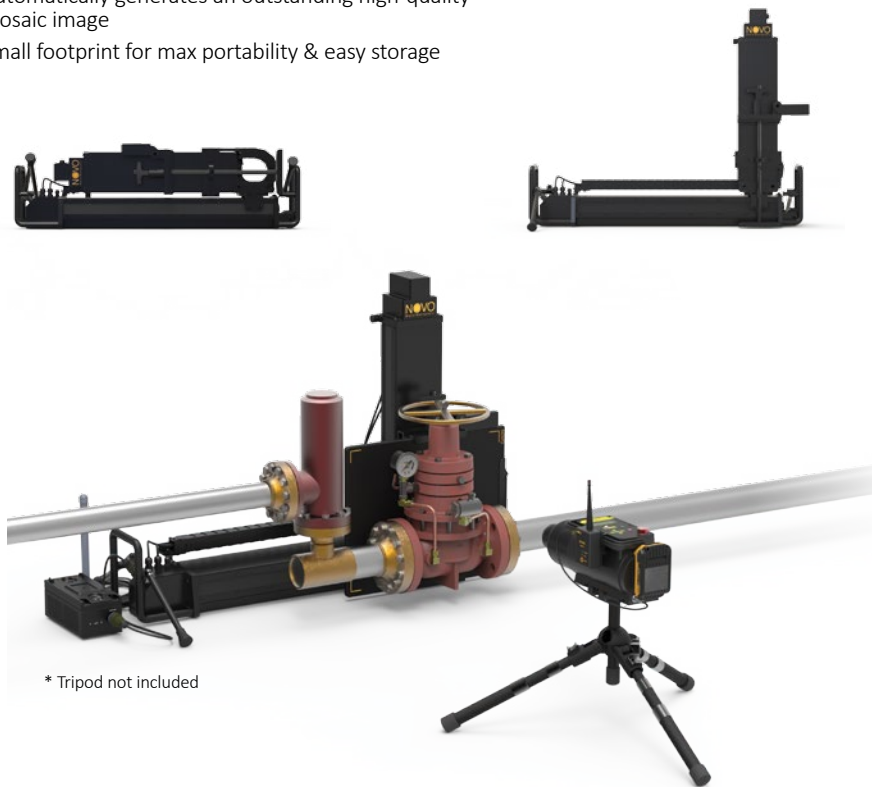

Figure b

## Folding Slider

The NOVO Folding Slider is the ideal solution for screening large objects.

- Screening area of 2X2 using the NOVO 22WN Detector
- Screening area of 3X2 using the NOVO 15WN Detector
- Controlled by the NOVO Touch Software
- Completely automated movement
- Automatically generates an outstanding high-quality mosaic image
- Small footprint for max portability & easy storage



	NOVO 15 WN Detector	NOVO 22 WN Detector
Grabbing Size	3x2	2x2
Folding Slider ~Size (folded)	37.4" x 13.8" x 7.9" (95cm x 35cm x 20cm)	
NOVO Folding Slider Rugged 1740 Pelican™ Case	44.2" x 16.1" x 14.0" (112.2cm x 40.9cm x 35.6cm)*	

\*External Dimensions

## Lookout

The NOVO Lookout is a Lightweight, 3 in 1 accessory enabling the following capabilities.

### Live Video

- Provides a Live Video stream of the inspected item
- The Camera switches automatically between day / night mode (Infra-red)
- Provides a still Image that can be saved and used for analysis and documentation

### Live Audio

- Provides a Live Audio stream of the inspected environment allowing the operator to monitor the sounds in the surrounding area

### Organic Detection

- Assists in identification of the content and nature of an inspected item by providing organic / in-organic detection
- Controlled completely by the NOVO Touch Professional Software
- Compatible with Golden Engineering XR150, XR200 and XRS-3 sources



# NOVO

Digital Radiography

---

## The Leaders in Portable DR Systems

NOVO DR Ltd. is the leading developer and manufacturer of cutting edge, Portable, Digital Radiography (DR) X-Ray Inspection Systems for the NDT & Security industries.

Having the most experienced team in the Portable DR world, NOVO plays a key role in the industry selling field proven, X-Ray Inspection Systems to prominent organizations globally. We are constantly working on developing new products that take the DR Market to the next level.

Today, NOVO provides the best of its kind portable, digital radiography systems emphasizing the following strong points:

- Highest Image Quality
- Ruggedness & System Reliability
- Portability
- Fast & Courteous Customer Support
- Fieldwork Optimization

[www.NOVO-DR.com](http://www.NOVO-DR.com)



INNOVATIVE • COMPACT • RUGGED